

SPRINGLOADED PRESSURE REGULATOR RS(H)8

GASES • WATER • ACIDS • OILS



MAIN FEATURES

- ss 316L
- balanced valve
- Cv 2.07
- diaphragm or piston sensing
- choice of o-ring materials
- shell design according to EN 12516
- delivery according to PED

CHARACTERISTICS

- Inlet pressure : 70 bar, 400 bar
Outlet ranges:
- Diaphragm sensing : 0 – 14 bar
 - Piston sensing : 0 – 400 bar
- Seat diameter : 10 mm
Cv (Kv) : 2.07 (1.79)
Materials:
- Body & Trim : ss 316L
 - Springhousing : ss 316L
 - Seat insert : RS8: elastomer
RSH8: pctfe, peek
elastomer
- Seals
Connections:
- Line : 1" bspp, flanges to DIN / ANSI B16.5
 - Gaugeport : 1/4" npt
- Weight : 4,5 kg (without flanges)
Temperature range : -20°C to +80 °C *

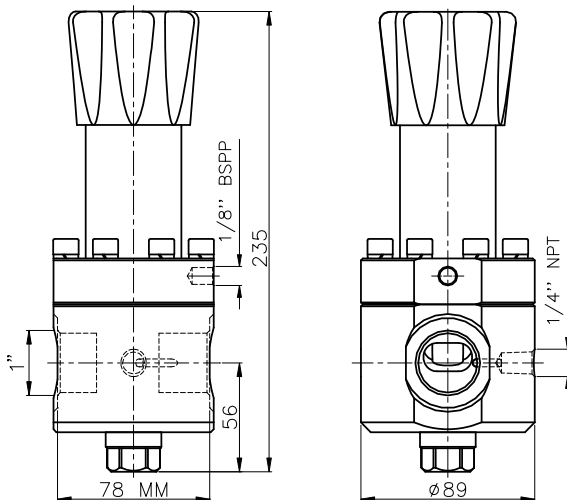

PORTING STYLE

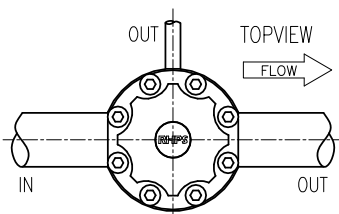

CLEANING

This regulator is ultrasonically cleaned and degreased. Oxygen cleaning based on ASTM-G93 Level C / CGA 4.1 is optional.

Do not use teflon tape or anaerobic sealing compounds on the bspp threads.

* Actual range depends on choice of seat- and seal material.

⚠ Swagelok regulators are not “Safety Accessories” as defined in the Pressure Equipment Directive 97/23/EC:

⚠ Do not use the regulator as a shut off device.

RHPS Series

Swagelok

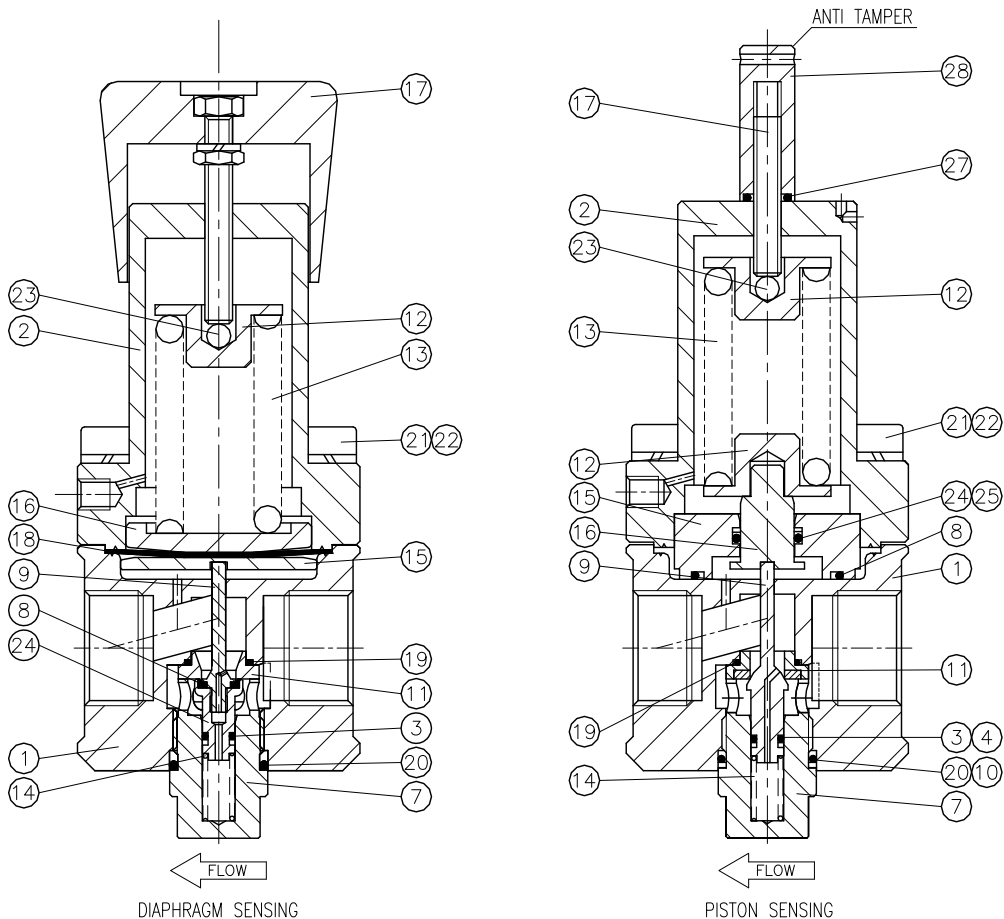

GAUGEPORT(S)

standard:



options:



GN2
(not in combination with flanges)



GN4



GN5
(not in combination with flanges)

ORDERING INFORMATION

example: **RSHB8-02-5-NNK-A**

RSH	B8	- 02	- 5	- N	N	K	- A	
series / inlet	connection	flange facing*	material	outlet range	o-rings	diaphragm	seat	options
RS = 70 bar RSH = 400 bar	B8 = 1" bsp N8 = 1" npt ANSI flanges FA8A = 1" class 150 FA8B = 1" class 300 FA8C = 1" class 600 FA8E = 1" class 1500 FA8F = 1" class 2500 Din flanges FD8M = DN25 PN16 FD8N = DN25 PN40 FD8P = DN25 PN64 FD8R = DN25 PN250 FD8S = DN25 PN400	(if flanges are ordered) 1 = raised face smooth 3 = RTJ	02 = ss316L	RS: <i>diaphragm sensing:</i> 1 = 0 - 3 bar 2 = 0 - 7 bar 3 = 0 - 14 bar <i>piston sensing:</i> 4 = 0 - 28 bar 5 = 0 - 40 bar RSH: <i>diaphragm sensing:</i> 1 = 0 - 3 bar 2 = 0 - 7 bar 3 = 0 - 14 bar <i>piston sensing:</i> 4 = 0 - 28 bar 5 = 0 - 40 bar 6 = 0 - 80 bar 7 = 0 - 150 bar 9 = 0 - 280 bar 11 = 0 - 400 bar	N = nitrile E = epdm V = viton	N = nitrile E = epdm V = viton <i>piston o-rings:</i> N = nitrile E = epdm V = viton	RS: N = nitrile E = epdm V = viton RSH: K = pctfe P = peek	A = anti-tamper G* = gaugeport * see gauge port options

Red text identifies an example ordering number.

FLOWCURVES RS8-02-1 / RS8-02-2 / RS8-02-3 / RS8-02-4

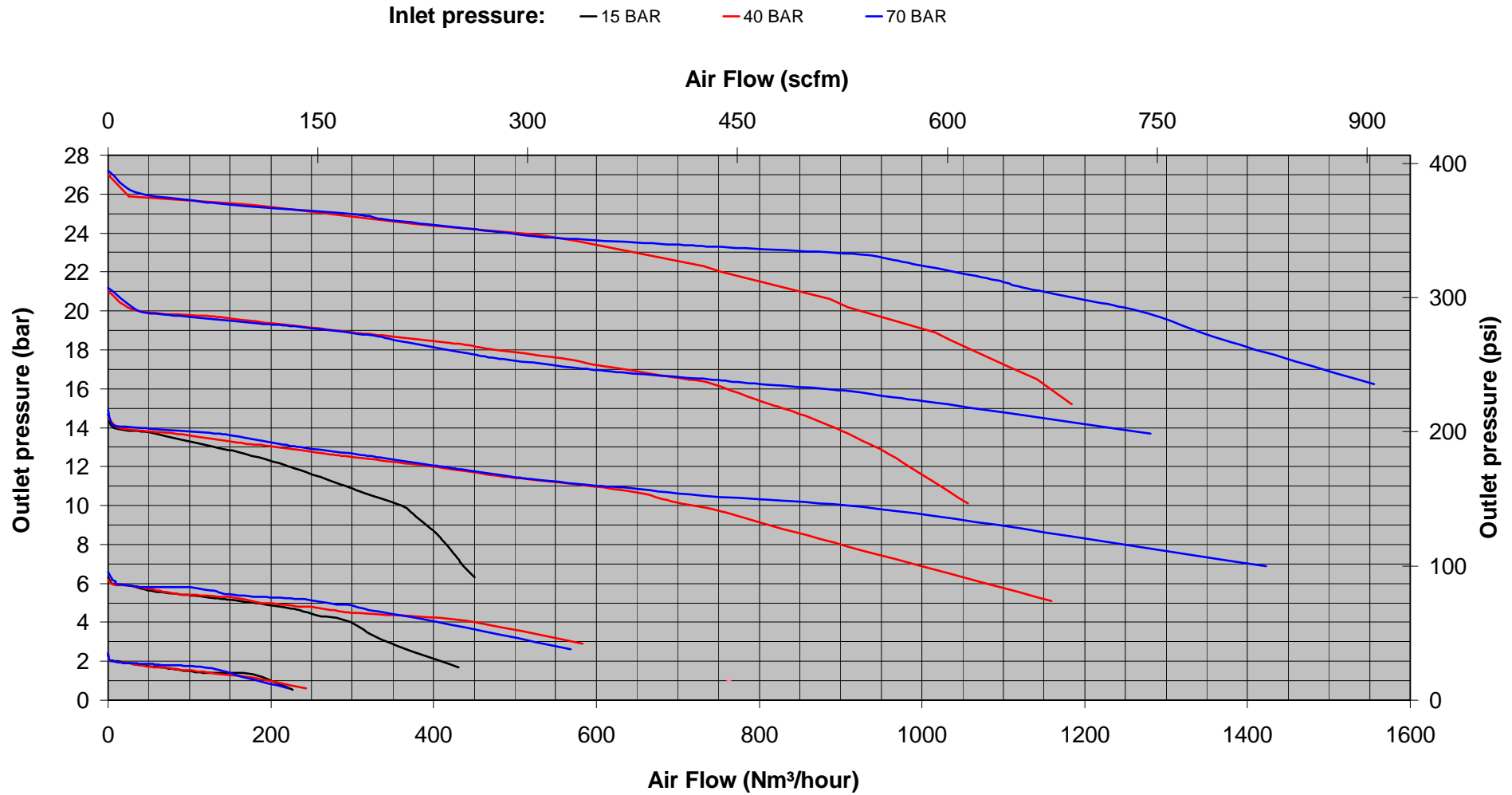

FLOWCURVES RS8-02-4 / RS8-02-5 / RS8-02-6

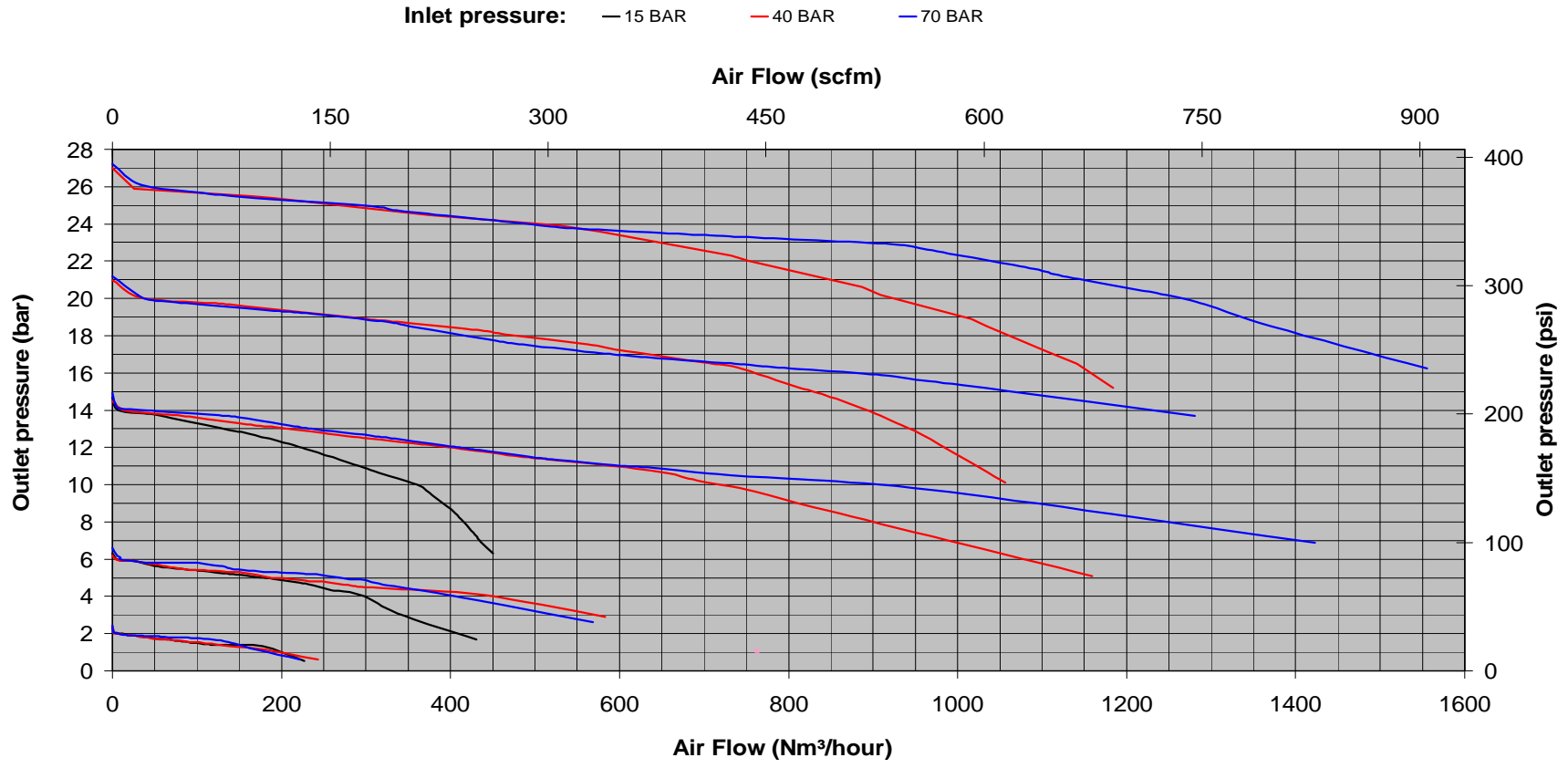

Safe Product Selection
 When selecting a product, the total system design must be considered to ensure safe, trouble-free performance. Function, material compatibility, adequate ratings, proper installation, operation, and maintenance are the responsibilities of the system designer and user.

RHPS, Swagelok—TM Swagelok Company
 © 2010 Swagelok Company
 Printed in U.S.A., OM
 June 2010, R0
 MS-02-381-E

RHPS Series

